

alber®

# ESPRIT

**Informationen für Therapeuten und Fachhändler**  
Programmierfunktionen · Modellreihe E34z

DE

**Information for Therapists and DME Dealers**  
Programming and Service Guide · Model E34z

EN

**Informations pour thérapeutes et revendeur spécialisés**  
Les fonctions de programmation · Modèles E34z

FR

**Información para terapeutas y comercios especializados**  
Funciones de programación · Serie de modelos E34z

ES

**Informatie voor therapeuten en vakhandelaars**  
Programmeringsfuncties · Modelreeks E34z

NL

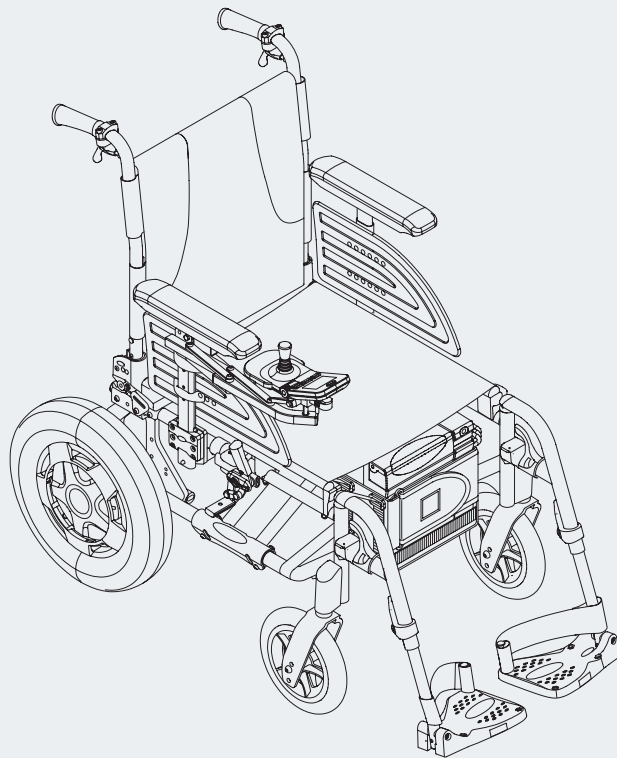

CE

<b>Contents</b>	
<b>1. Parameters</b>	<b>2</b>
1.1 "System" menu	2
1.2 "User mode" menu	2
1.3 "Attendant control" menu	3
<b>2. Programming</b>	<b>4</b>
2.1 Overview of menu structure and associated buttons on the control unit	5
2.2 "Programming" menu	6
2.3 "System" menu	6
2.4 "User mode" menu	7
2.5 "Attendant control" menu	7
2.6 Finishing programming	8
<b>3. Parameter table</b>	<b>9</b>
<b>4. Error table</b>	<b>12</b>

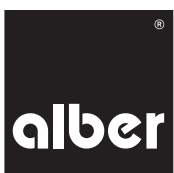

39.0003.4.99.01  
As of: 2021-03-16

This information for therapists and specialist dealers provides details on these products:

- Esprit E34z, up to 125 kg user weight, size of wheels 14"
- e-fix eco, up to 120 kg user weight, size of wheels 22" and 24" both called "esprit" in the following.

## 1. Parameters

To meet the requirements of a diverse range of disabilities and customer requirements, the Esprit offers a wide range of user parameters that can be modified. Programming can be performed as described in chapter 2, directly using the control unit without an additional device.

The following parameters are stored in the *system*, *user mode*, *attendant control* and *Opti-Box*. Changes to these parameters can be made directly using the control unit (see chapter 2), please refer to the table in chapter 3 for the possible settings.



**Only the authorised specialist dealer can make any of the settings, under no circumstances can the wheelchair user do this themselves. Similarly, the programming key included with this delivery must not be given to the wheelchair user.**

### 1.1 "System" menu

#### Brake applied

- A time delay until the electromagnetic parking brakes deploy once the last drive command (joystick deflection) has been issued.
- In the factory setting the brakes are applied after 30 seconds. Continuous braking is avoided which means there is no unwanted annoying "clicking" noise.
- Immediately: if you need to come to a safe stop immediately, for example when approaching slightly inclined kerbs/steps.

#### Automatic cut-off

- The time it takes until the Esprit automatically cuts off to protect the battery pack.

#### Menu function

- Option of completely deactivating the menu function, i.e. all the setting options for the end customer. Specialist dealer access is preserved.

#### Joystick deflection

- Reduces the required deflection to reach the maximum speed from 100% to 80%, 60% and 40%.

#### Joystick axle change

Various settings to change the four directions of travel.



**If the "axle change" parameter has been changed, the Esprit may only be operated using the bumper bar for the control unit (item no. 1565836).**

#### Set factory settings

- Resets all functions of the Esprit to the delivery condition upon leaving the factory.
- All customised settings are deleted and the language will need to be reselected.

### 1.2 "User mode" menu

The settings made in this menu affect the driving characteristics with which the wheelchair user controls the Esprit themselves.

#### Maximum speed forwards

Specifies the maximum achievable speed going forwards.

- We recommend reducing the speed for beginners or when the wheelchair is being used exclusively indoors.
- It is also sensible to reduce the speed for elderly users.

#### Maximum speed backwards

Specifies the maximum achievable speed going backwards.

- For safety reasons this is a maximum of 70% of the forwards speed.
- Reduction if travel needs to be very slow (e.g. for wheelchair users with poor coordination, elderly users or when travelling indoors).

### **Acceleration**

The time it takes to reach the maximum speed.

- The user may also refer to this as “reaction” (prompt/slow).
- Reduce in the event of tremor or ataxia and for children’s wheelchairs (generally when the wheelchair and wheelchair user are light-weight).
- Increase to better overcome minor obstacles at low speeds e.g. indoor thresholds.

### **Delay**

The time it takes to brake from the maximum speed to the required drive speed or to come to a stop.

- Reduce if very smooth wheelchair handling is required at low speeds, for example, for users with low upper body tone/core stability.
- Increase at low speeds if precise driving (e.g. in a narrow living room) or quick reaction is required.

### **Turning speed**

Determines the maximum speed at which you can drive in a circle or around a bend.

- Reduction results in more stable straight-line driving at high speeds, slow/forgiving at low speeds, for example with attendant control.
- Increasing at low speeds (indoors) supports driving around tight corners, at high speeds the wheelchair is sensitive/quick to react.

### **Turning acceleration**

The time it takes to reach the maximum turning speed.

- It is also generally described as sensitivity/reaction.
- Increasing this parameter results in quicker reaction/acceleration.
- Reduce to adapt to tremor or ataxia or for attendant control.

## **1.3 “Attendant control” menu**

The settings made in this menu affect the intuitive attendant control, which is available as an optional accessory and which is operated by the wheelchair user’s attendant. It has the same parameters that have been described in chapter 1.2 (indep.user mode menu). In addition the menu includes the sensor deflection parameter.

### **Sensor deflection**

- Reduces the required deflection to reach the maximum turning speed from 100% to 80%, 60% and 40%.

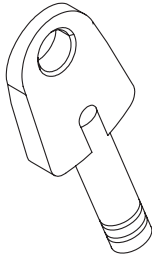

## 2. Programming

The different menus are navigated in the same way as described in the Esprit operating manual. You also need the programming key (red) illustrated in the accompanying diagram, which is included with every new Esprit delivery.

Parameters are selected and modified using the control unit joystick. Deflecting the joystick up or down enables you to navigate through the menus, deflecting the joystick sideways to the left or right makes settings to the different parameters, described in detail in the following.

Buttons [22] to [24] enable you to select, save or test the modifications you have made or leave a menu level.

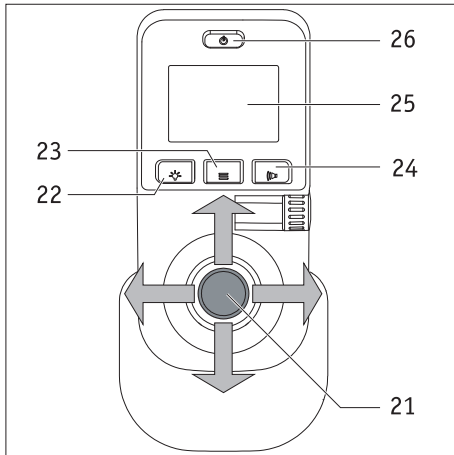

**The programming key must not be handed over to the user for safety reasons. The driving parameters may only be modified by qualified personnel (therapists, specialist dealers).**



**Adapting the various parameters should always be performed in the presence of the wheelchair user because they can then test the modifications immediately. Should this not be possible, after reprogramming the user should take a test drive under the supervision of specialist personnel to ensure that the user can cope with the new driving characteristics.**

2.1 Overview of menu structure and associated buttons on the control unit

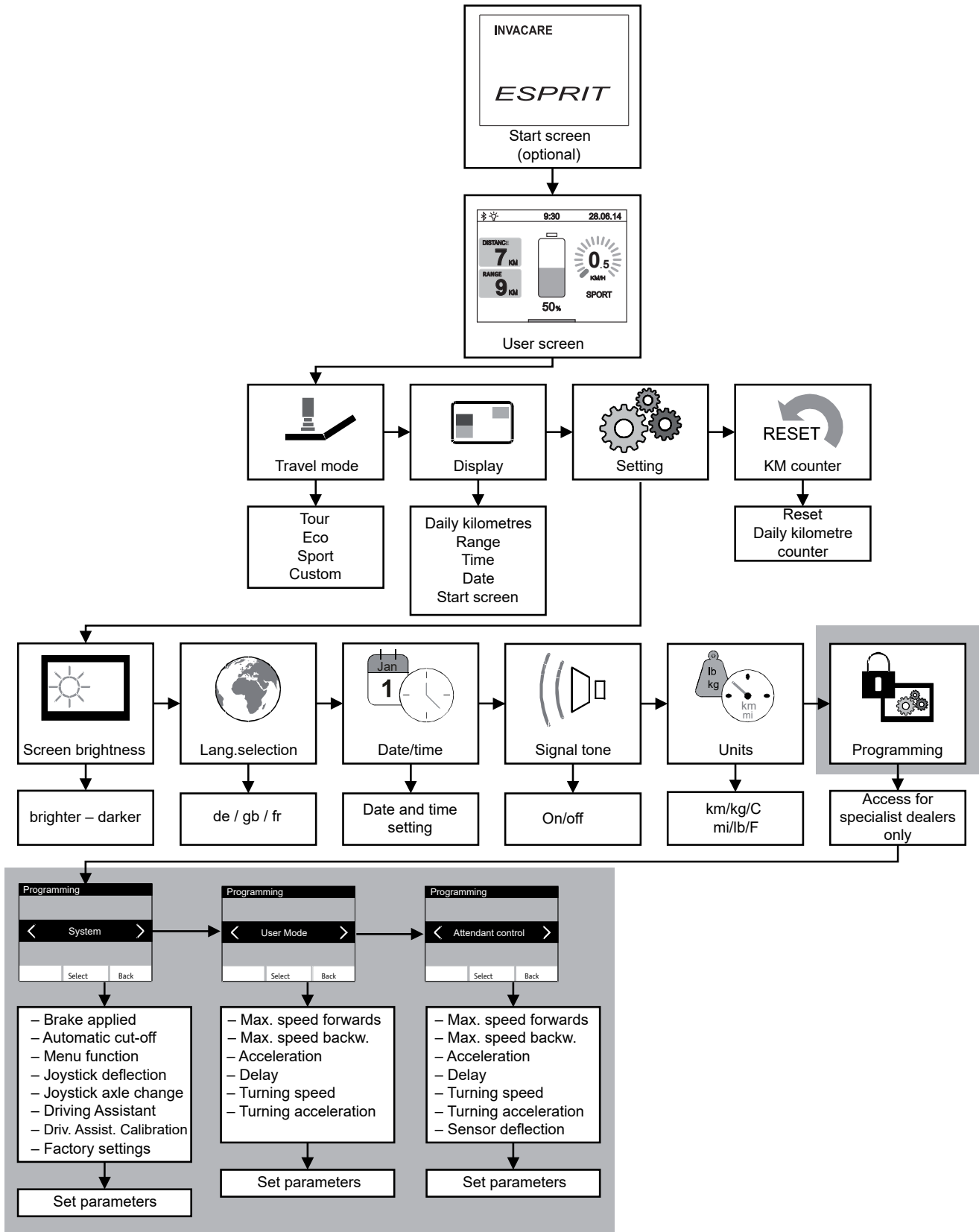

The level highlighted in grey can only be accessed by the specialist dealer or therapist. Access requires a programming key.

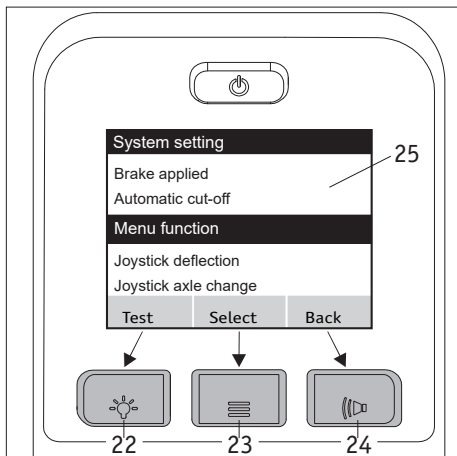

The control unit buttons are assigned to the menus and sub menus as follows:

- **“Save” or “Test” display** (double assignment)  
Saving or testing a parameter: press button [22]
- **“Select” display**  
Jumps to a menu or sub menu: press button [23].
- **“Back” display**  
One level back (without saving!): press button [24].

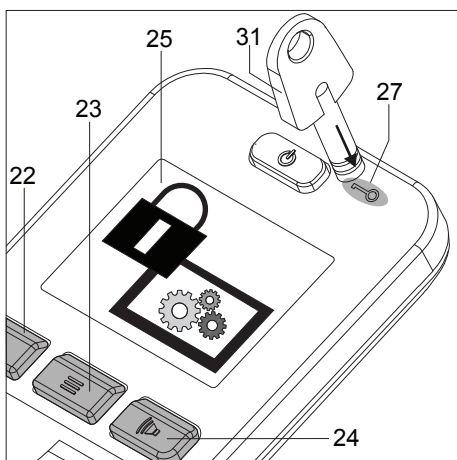

## 2.2 “Programming” menu

The Esprit operating manual, from chapter 5.3, describes how to navigate through the different menus.

To reach the *programming* menu, which is only accessible to specialist dealers and therapists, navigate using the joystick and buttons from the user screen to *settings* and then to *programming* (see also the menu structure in chapter 2.1).

Now lay the key [31] on field [27] and press button [23].

The system switches to the sub menus of *system*, *user mode*, and *attendant control*.

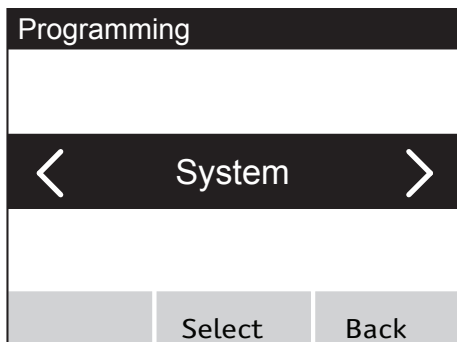

## 2.3 “System” menu

- In the system menu press on button [13] to reach the parameters which are described in more detail in chapter 1.1.1.

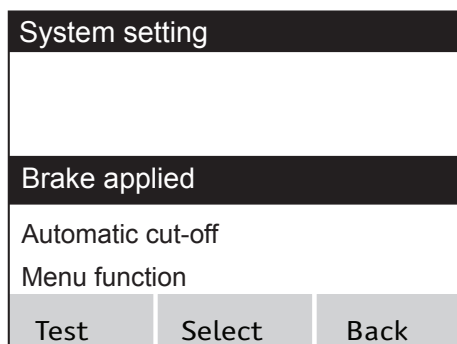

- Move the joystick [21] forwards or backwards to move the parameters through a black bar on the display.
- If the required parameter is highlighted by the black bar you can access any possible settings by pressing button [23] (the accompanying diagram shows the parameter “brake applied”).
- You are now in menu function.

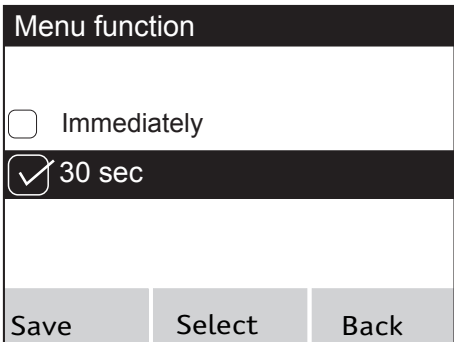

- Move the joystick [21] forwards or backwards once again. This moves the different setting options through the black bar.
- If the required setting is highlighted by the black bar, it can be activated by pressing button [23] or by moving the joystick [21] to the left or right. When the parameter is active, a ticked square is displayed to the left.
- Press button [22] on the control unit to save the setting, or button [24] to exit the menu without saving the chosen setting.
- You are now automatically taken back to the system setting level.

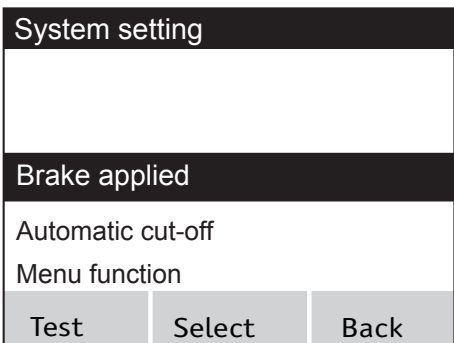

- In the setting system menu you can now
  - Set further parameters,
  - Leave the menu by pressing button [24]
  - Test the changes you have made by pressing button [22].

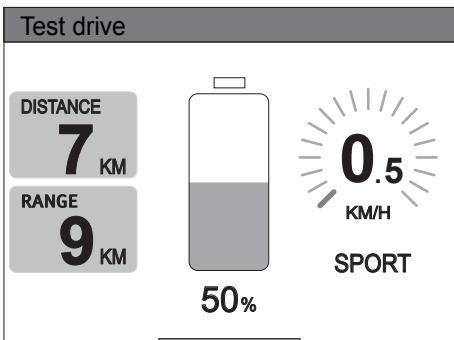

Testing the changes made

- Pressing button [22] takes you directly to the user screen which now displays a purple bar at the top of the screen with the words “test drive”.
- Test the changed parameters
- Exit the user screen by pressing button [23]. This automatically takes you back to the *system setting* level where you can make further settings.
- When you have finished with the settings, press button [24] to go back to the *user screen*.

**2.4 “Indep.user mode” menu**

Navigating to the menu and setting the parameters is performed in the same way as described in detail in chapter 1.3. The parameters contained in the *indep.user mode* menu relate to driving with the Esprit control unit. The parameters listed in chapter 1.1.2 can be adapted:

**2.5 “Attendant control” menu**

The parameters contained in the *attendant control menu* relate exclusively to the intuitive attendant control that is fitted to the Esprit and which is supplied by Alber as an accessory.

The parameters listed in chapter 1.1.3 can be adapted:



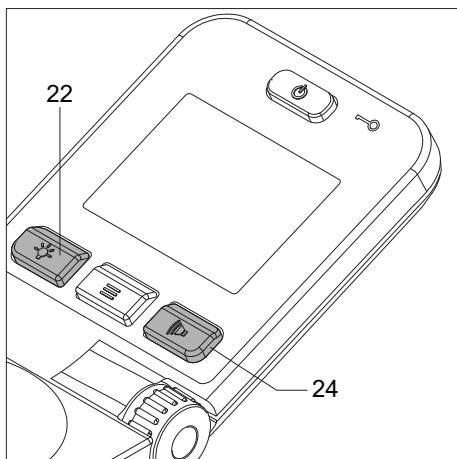

## 2.6 Finishing programming

You can finish programming the parameters at any time. To do this press button [24] several times until you reach the user screen.

Please note that when you exit the programming menu the parameters that you changed are not saved automatically – you need to press button [22].

If parameters are reprogrammed, the wheelchair user needs to take a test drive under the supervision of specialist personnel to test the new driving characteristics and ensure that the user can cope with the new driving characteristics.

### 3. Parameter table

#### System

Description	Selectable parameters
Brake applied	<ul style="list-style-type: none"> <li>• Immediately</li> <li>• <b><u>30 seconds</u></b></li> </ul>
Automatic cut-off	<ul style="list-style-type: none"> <li>• <b><u>10 minutes</u></b></li> <li>• 20 minutes</li> <li>• 30 minutes</li> <li>• 1 hour</li> <li>• 2 hours</li> <li>• 4 hours</li> <li>• 8 hours</li> </ul>
Menu function	<ul style="list-style-type: none"> <li>• Off</li> <li>• <b><u>On</u></b></li> </ul>
Joystick deflection	<ul style="list-style-type: none"> <li>• <b><u>100%</u></b></li> <li>• 80%</li> <li>• 60%</li> <li>• 40%</li> </ul>
Joystick axle change	<ul style="list-style-type: none"> <li>• <b><u>Standard</u></b></li> <li>• forwards/backwards</li> <li>• right/left</li> <li>• both axles</li> </ul>

Description	Selectable parameters
Driving Assista (1) <i>(Applies only to Esprit E34z)</i>	<ul style="list-style-type: none"> <li>• <b><u>Activate</u></b></li> <li>• Deactivate</li> </ul>
Driving Assistant Calibration (2) <i>(Applies only to Esprit E34z)</i>	<ul style="list-style-type: none"> <li>• Calibrate now</li> </ul>
Set factory setting	<ul style="list-style-type: none"> <li>• Yes</li> <li>• No</li> </ul>

#### Factory pre-sets

Factory pre-sets are **bold** and underlined

#### (1) Note on the Driving Assistant parameter

The driving assistant supports the user while driving. If the gyro sensor in the control unit detects a slope, the software of the Esprit automatically reduces the acceleration of the system to prevent tipping onto the anti-tippers. Only deactivate the driving assistant if the drive system has been installed on a wheelchair that has a sufficiently long wheelbase and a fixed backrest that cannot be adjusted or folded down. Only then is the tipping stability of the system still ensured. For this reason, anti-tippers must always be used in pairs. The system must not be operated without anti-tippers.

If the driving assistant is deactivated, the gyro symbol at the top left of the status bar on the control unit disappears.

#### (2) Note on the Driving Assistant Calibration parameter

The driving assistant must be calibrated if a new swivel arm or a new bracket for the control unit is attached to the Esprit. For this purpose, the Esprit must be placed on a flat, horizontally level surface.

The calibration is performed immediately when you confirm "Calibrate now".

## User Mode

Description	Selectable parameters	Description	Selectable parameters
Maximum speed forwards	<ul style="list-style-type: none"> <li>• <b><u>8.0 km/h 4.97 mph</u></b> ****</li> <li>• <b><u>6.0 km/h 3.73 mph</u></b> ***/**</li> <li>• <b><u>5.0 km/h 3.11 mph</u></b> *</li> <li>• 4.0 km/h 2.49 mph</li> <li>• 3.0 km/h 1.86 mph</li> <li>• 2.5 km/h 1.55 mph</li> <li>• 2.0 km/h 1.24 mph</li> <li>• 1.5 km/h 0.93 mph</li> <li>• 1.0 km/h 0.62 mph</li> </ul>	Delay	<ul style="list-style-type: none"> <li>• 1.5 seconds</li> <li>• 2.0 seconds</li> <li>• 2.5 seconds</li> <li>• 3.0 seconds</li> <li>• 3.5 seconds</li> <li>• <b><u>4.0 seconds</u></b> **/*</li> <li>• <b><u>5.0 seconds</u></b> ****/****</li> <li>• 6.0 seconds</li> </ul>
Maximum speed backwards	<ul style="list-style-type: none"> <li>• 70%</li> <li>• 60%</li> <li>• <b><u>50%</u></b> */**/****</li> <li>• <b><u>40%</u></b> ****</li> <li>• 30%</li> </ul>	Turning speed	<ul style="list-style-type: none"> <li>• 40%</li> <li>• 35%</li> <li>• 30% ***</li> <li>• 25%</li> <li>• 20% ****/**</li> <li>• 15% *</li> <li>• 10%</li> </ul>
Acceleration	<ul style="list-style-type: none"> <li>• 1.0 seconds</li> <li>• 1.5 seconds</li> <li>• 2.0 seconds</li> <li>• 2.5 seconds</li> <li>• <b><u>3.0 seconds</u></b> ***</li> <li>• 3.5 seconds</li> <li>• <b><u>4.5 seconds</u></b> ****/**</li> <li>• 5.0 seconds</li> <li>• <b><u>6.0 seconds</u></b> *</li> </ul>	Turning acceleration	<ul style="list-style-type: none"> <li>• <b><u>0.04 seconds</u></b> ***</li> <li>• 0.06 seconds</li> <li>• <b><u>0.08 seconds</u></b> ****/**/*</li> <li>• 0.10 seconds</li> <li>• 0.15 seconds</li> <li>• 0.20 seconds</li> <li>• 0.25 seconds</li> </ul>

### IMPORTANT

When the Esprit is initially delivered, the parameters visible in the table (**bold** and underlined) are predefined as the factory settings for the drive modes ECO\*, TOUR\*\*, SPORT\*\*\* and SPEED\*\*\*\*. However, when the *Programming-Indep.user mode* menu is called up, only the factory settings for TOUR drive mode are displayed on the control unit's display screen. The parameters for the SPEED mode are only for info, it according to safety reasons not possible to set a CUSTOM drive mode with a max. speed of 8 km/h.

If one of the parameters is changed, it affects all the drive modes - ECO, TOUR, SPORT and Speed are then no longer available for selection. Instead, the control unit's display screen indicates CUSTOM mode, which comprises all the selected parameters in the *Programming-Indep.user mode* menu.

ECO, TOUR, SPORT and Speed can be restored to the settings specified in the table at any time using *Programming-System-Set factory settings*.

## Attendant control

Description	Selectable parameters
Maximum speed forwards	<ul style="list-style-type: none"> <li>• 6.0 km/h 3.73 mph</li> <li>• <b><u>5.5 km/h 3.42 mph</u></b></li> <li>• 5.0 km/h 3.11 mph</li> <li>• 4.0 km/h 2.49 mph</li> <li>• 3.0 km/h 1.86 mph</li> <li>• 2.5 km/h 1.55 mph</li> <li>• 2.0 km/h 1.24 mph</li> <li>• 1.5 km/h 0.93 mph</li> </ul>
Maximum speed backwards	<ul style="list-style-type: none"> <li>• 70%</li> <li>• 60%</li> <li>• <b><u>50%</u></b></li> <li>• 40%</li> <li>• 30%</li> </ul>
Acceleration	<ul style="list-style-type: none"> <li>• 1.5 seconds</li> <li>• 2.0 seconds</li> <li>• 2.5 seconds</li> <li>• 3.0 seconds</li> <li>• 3.5 seconds</li> <li>• <b><u>4.0 seconds</u></b></li> <li>• 4.5 seconds</li> </ul>
Delay	<ul style="list-style-type: none"> <li>• 2.0 seconds</li> <li>• 2.5 seconds</li> <li>• 3.0 seconds</li> <li>• 3.5 seconds</li> <li>• <b><u>4.0 seconds</u></b></li> <li>• 5.0 seconds</li> <li>• 6.0 seconds</li> </ul>

Description	Selectable parameters
Turning speed	<ul style="list-style-type: none"> <li>• 40%</li> <li>• 35%</li> <li>• 30%</li> <li>• <b><u>25%</u></b></li> <li>• 20%</li> <li>• 15%</li> <li>• 10%</li> </ul>
Turning acceleration	<ul style="list-style-type: none"> <li>• 0.06 seconds</li> <li>• <b><u>0.08 seconds</u></b></li> <li>• 0.10 seconds</li> <li>• 0.15 seconds</li> <li>• 0.20 seconds</li> <li>• 0.25 seconds</li> </ul>
Sensor deflection	<ul style="list-style-type: none"> <li>• <b><u>100%</u></b></li> <li>• 80%</li> <li>• 60%</li> <li>• 40%</li> </ul>

### Factory pre-sets

Factory pre-sets are **bold** and underlined

#### 4. Error table

Display	Fault	Remedy
B10	Energy recovery is not possible because the battery pack has too much power	Switch the system off and on again. Continue driving, uphill if possible.
B11	Energy recovery too high, speed is reduced	Drive carefully. Avoid driving downhill.
B12	Energy recovery high	Reduce speed. Avoid driving downhill.
B13	Discharge current too high	Switch the system off and on again. Continue driving with caution.
B14	Discharge current too high, speed is reduced	Continue driving with caution. Avoid driving uphill.
B15	Discharge current high	Reduce speed. Avoid driving uphill.
B16	Battery pack voltage is too low	Charge the battery pack.
B17	Battery voltage too low, speed is reduced	Charge the battery pack.
B18	Battery pack voltage is low	Charge the battery pack.
B19	Voltage in the battery pack is too high during recovery	Switch the system off and on again. Continue driving with caution.
B20	Battery pack voltage is too high	Switch the system off and on again. Continue driving with caution.
B21	Energy recovery is not possible because the battery temperature is too low	Switch the system off and on again. Continue driving with caution.
B22	Battery pack temperature too low, speed is reduced	Continue driving with caution. Avoid driving downhill.
B23	Battery pack temperature low	Reduce speed. Avoid driving downhill.
B24	Battery pack temperature too low	Switch the system off and on again. Continue driving with caution.
B25	Battery pack temperature too low, speed is reduced	Continue driving with caution. Avoid driving up and down slopes.
B26	Battery pack temperature low	Reduce speed. Avoid driving up and down slopes.
B27	Energy recovery is not possible because the battery pack temperature is too high	Switch the system off and on again. Continue driving with caution.
B28	Battery temperature too high, speed is reduced	Continue driving with caution. Avoid driving up and down slopes.
B29	Battery pack temperature high	Reduce speed. Avoid driving up and down slopes.
B30	Battery pack temperature too high	Switch the system off and on again. Continue driving with caution.
B31	Battery pack temperature too high, speed is reduced	Continue driving with caution. Avoid driving up and down slopes.
B32	Battery pack temperature high	Reduce speed. Avoid driving up and down slopes.
B33 to B37	Battery pack electronics fault	Switch the system off and on again. If the error occurs again: send the battery pack to Alber for servicing.
B38	Residual capacity of the battery pack low, end of service life reached	Send the battery pack to Alber for servicing.
B39	Defective temperature sensor in battery pack	Switch the system off and on again. If the error occurs again: you need a new battery.

Display	Fault	Remedy
C10 to C15	Defective joystick signal	Replace joystick. If the error occurs again: you need a new control unit.
C16, C17	Defective speed pre-set signal	You need a new control unit.
C19 to C25	Control unit electronics fault	Switch the system off and on again. If the error occurs again: you need a new control unit.
C26	Display memory fault	Switch the system off and on again. If the error occurs again: you need a new control unit.
C27	Immobiliser sensor fault	Switch the system off and on again. If the error occurs again: you need a new control unit.
C28	Joystick was extended on start-up	Do not touch the joystick when switching the system on. If the error occurs again: you need a new control unit.
C30	Slope too great	<ul style="list-style-type: none"> <li>• Check that the control unit is mounted horizontally.</li> <li>• If the bracket of the control unit is misaligned or bent, realign it to the original horizontal position and recalibrate the gyro sensor on a flat, horizontally level surface.</li> </ul>
C31	Gyro sensor error	<ul style="list-style-type: none"> <li>• No communication with the sensor is possible.</li> <li>• Switch the system off and back on again.</li> <li>• If the error occurs again: Contact the Alber service center.</li> </ul>
I04	Attendant control communication fault	Switch the system off and on again. If the error occurs again: send the attendant control to Alber for servicing.
I05	Attendant control button was pressed on start-up	Switch the system off and on again. If the error occurs again: send the attendant control to Alber for servicing.
I08, I09	Attendant control collision protection was activated	Deactivate attendant control. Switch the system off and on again. If the error occurs again: send the attendant control to Alber for servicing.
M10	Check electronics, left drive failure	Switch the system off and on again. If the error occurs again: you need a new drive wheel.
M11	Check electronics, right drive failure	Switch the system off and on again. If the error occurs again: you need a new drive wheel.
M12	Left drive voltage range fault	Switch the system off and on again. Replace the left wheel on the right-hand side. If the error occurs again: check that the battery pack and cabling is working properly. If the error changes from M12 to M13: send the wheel to Alber for servicing.
M13	Right drive voltage range fault	Switch the system off and on again. Replace the left wheel on the right-hand side. If the error occurs again: check that the battery pack and cabling is working properly. If the error changes from M13 to M12: send the wheel to Alber for servicing.
M14, M15	Drive temperature range error	Reduce speed. Allow the drives to cool. If the error occurs again: send the wheels to Alber for servicing.

Display	Fault	Remedy
M16, M17	Drive overload error	The load is too high for the drives. Avoid overloading.
M18, M19	Drive load is too high	The load is too high for the drives. Avoid overloading.
M20, M22, M24, M26, M28	Right drive electronics fault	Switch the system off and on again. If the error occurs again: you need a new wheel.
M21, M23, M25, M27, M29	Left drive electronics fault	Switch the system off and on again. If the error occurs again: you need a new wheel.
M30, M32	Right drive rotor position sensor fault	Switch the system off and on again. If the error occurs again: you need a new wheel.
M31, M33	Left drive rotor position sensor fault	Switch the system off and on again. If the error occurs again: you need a new wheel.
M34, M36, M38, M40, M42, M44, M46, M48, M50	Right drive electronics fault	Switch the system off and on again. If the error occurs again: you need a new wheel.
M35, M37, M39, M41, M43, M45, M47, M49, M51	Left drive electronics fault	Switch the system off and on again. If the error occurs again: you need a new wheel.
M52	Right drive disengaged	Couple drive.
M53	Left drive disengaged	Couple drive.
M54	Left and right drive disengaged	Couple drives.
M55, M56	High drive temperature	Reduce speed. Allow the drives to cool.
S10	Cannot communicate with the right drive	Switch the system off and on again. Replace the right wheel on the left-hand side. If the error occurs again: renew cabling, send the wheel to Alber for servicing.
S11	Cannot communicate with the left drive	Switch the system off and on again. Replace the left wheel on the right-hand side. If the error occurs again: renew cabling, send the wheel to Alber for servicing.
S12	Cannot communicate with the battery pack	Switch off the system, unplug the control unit from the battery pack, remove the battery pack from the battery holder. Reinsert the battery pack in the battery holder and connect the control unit If the error occurs again you need a new battery pack.
S13	No system communication	Check the plug connections. If the error occurs again: send the system to Alber for servicing.
S14	Drive encoding failure	Send both wheels to Alber for servicing.



When sending a defective component, please specify the error code that appeared in the control unit display as well as a detailed error report.





Ihre Alber-Vertretung / Your Alber representative / Votre représentation Alber /  
Vostra rappresentanza Alber / Su representación Alber / Din Alber representant /  
Din Alber-agenturene / Uw distributeur Alber / Deres Alber-repræsentation



**Alber GmbH**

Vor dem Weißen Stein 14  
72461 Albstadt-Tailfingen

Telefon +49 (0)7432 2006-0

Telefax +49 (0)7432 2006-299

info@alber.de

www.alber.de